

FOR APPROVAL

NO	DATE	REVISION	DRAWN
▲			

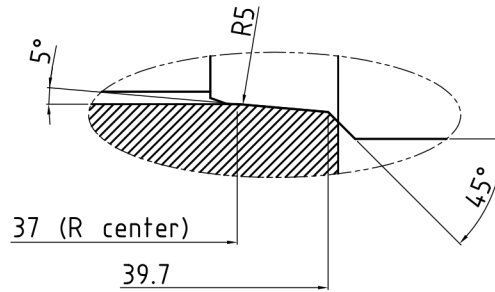
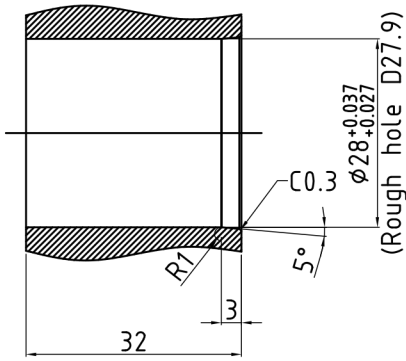
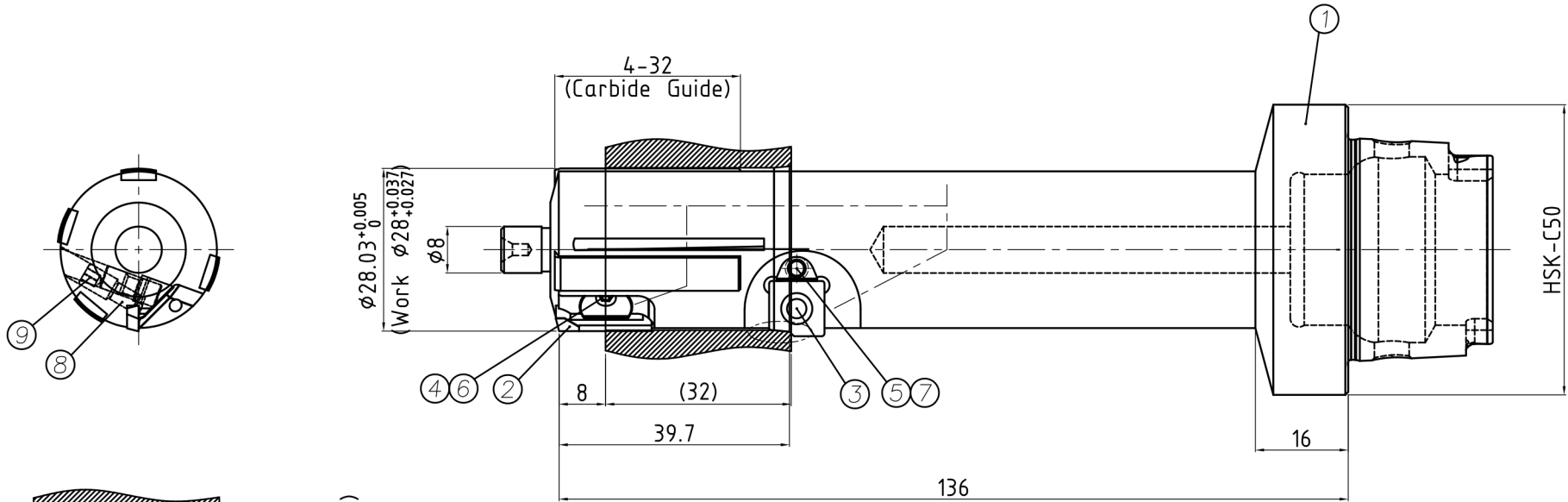

Detail Chamfer  
Scale (5:1)

9	PIN SCREW	M4xP0.7	2		
8	ADJUST PIN	MK3205-A45	2		(D3.2-L5-A45)
7	WEDGE SCREW	K368-04(M3/M4)	1		
6	WEDGE SCREW	MK368-07(M4-LH/RH)	1		M4 (LH/RH)
5	ADJUST WEDGE	K14884-13	1		
4	CLAMP WEDGE	GR-2N	1		
3	INSERT	SPGW090304-SPC	1		
2	BLADE	SZ92R6N	1		
1	BODY		1		

LENGTH LIMIT (mm)	ALLOWANCE			
	LENGTH	ANGLE	STRAIGHTNESS FLATNESS	PERPENDICULARITY
L ≤ 6	±0.1	±5'	0.05	0.4
6 < L ≤ 30	±0.2	±10'	0.1	0.4
30 < L ≤ 120	±0.3	±20'	0.2	0.4
120 < L ≤ 400	±0.5	±30'	0.4	0.6
400 < L	±0.8	±1°	0.6	0.8

Date	Designed	Checked	Approved
	Choi, J.H	Park, S.Y	Choi, S.J
CUSTOMER :			
PROJECT :			
DIM'S SCALE	mm Free	PROJECTION SIZE	3rd Free

TITLE :	FINE BORING TOOL
ITEM NO. :	
SPEC. :	
DWG. NO. :	
<b>MYKEYTOOL Co.,Ltd.</b>	